

A Collaborative Telemedicine Environment For the Ireland – Northern Ireland – National Cancer Institute International Partnership in Cancer Care

R. L. Martino¹, K. M. Kempner¹, F. S. Govern², D. Chow¹,
M. E. Steele¹, J. E. Elson¹, C. N. Coleman²

¹Division of Computational Bioscience, Center for Information Technology

²Radiation Oncology Sciences Program, National Cancer Institute

National Institutes of Health, Department of Health and Human Services, Bethesda, MD, USA

Abstract—The Ireland - Northern Ireland - National Cancer Institute Cancer Consortium was established to improve clinical cancer services and patient care on the island of Ireland, and to foster joint collaboration in cancer research and development. An important part of this Consortium was to develop telemedicine systems to facilitate collaboration between participating partners. We have implemented a telemedicine environment for the Consortium based on the TELESYNERGY® Medical Consultation WorkStation developed at the U.S. National Institutes of Health. The collaborative use of the system at the three sites has led to the improvement in quality of care in that each patient, regardless of location, can receive an expert assessment and given optimal therapy. The system will be a platform for collaborative clinical and translational research. In the future, this technology will be implemented at additional sites and applied to other medical specialties including cardiology, radiology, and infectious diseases.

Keywords—Telemedicine, multimedia integration, collaborative technologies, medical imaging

I. INTRODUCTION

A unique international program, known as the Ireland - Northern Ireland – National Cancer Institute (NCI) Cancer Consortium, was initiated in October 1999 for the purpose of the further development of cancer programs in Ireland and Northern Ireland, where cancer is a significant cause of mortality and morbidity [1]. The Department of Health and Children of Ireland, the Department of Health and Social Services of Northern Ireland, and the NCI of the United States Department of Health and Human Services, signed an historic Memorandum Of Understanding. This document formed a multilateral partnership among the three jurisdictions, with emphasis on improving clinical cancer services and patient care on the island of Ireland, and on fostering joint collaboration in cancer research and development.

The Consortium's goals are to (a) share the best available technology and enhance clinical research, (b)

conduct joint clinical research studies involving people from all jurisdictions, (c) sponsor formal training exchanges for Irish and American scholars in cancer programs in partner institutions, (d) implement the use of teleconferencing and other information technology capabilities to facilitate education, and (e) consolidate the Cancer Registries of Ireland and Northern Ireland and learn more about cancer incidence and trends on the entire island.

An important part of this Consortium, consisting of geographically distributed partners, was the development of useful telemedicine systems. The technologies that are essential ingredients of a successful telemedicine system are digital communications, digital video, digital imaging, and multimedia integration [2,3]. Digital communication systems allow for the efficient and accurate transmission of information and the multiplexing of information from many sources. As video conferencing is core to telemedicine, the benefits of digital video are needed to design interactive and flexible systems. Digital video typically requires very large storage and transmission bandwidth capacities, so video compression methods are needed in the implementation of practical systems.

Digital imaging modalities include computed tomography (CT), magnetic resonance imaging (MRI), positron emission tomography (PET) and microscope images. Traditional x-ray films, as well as any images recorded on film, can be added to the list of available images by converting the film into a digital format by an appropriate digitization process to preserve the required image quality for diagnosis. Telemedicine systems provide for the display and interactive analysis of these digital images. Multimedia integration allows the production, manipulation, presentation, communication, and storage of different types of media during a telemedicine session.

In addition to the appropriate use of these underlying technologies in the design of a system, advances in telemedicine also depend on the implementation of relevant applications. To emphasize the importance of application development, Mun and Turner [4] provided a framework for understanding the stages of telemedicine development after studying the use of a teleradiology system used in

neurosurgery and hemodialysis, and home telemedicine in diabetes care. They concluded that the evolution of a successful telemedicine implementation occurs through four stages: (1) the development of basic technological capabilities, (2) the development of relevant applications, (3) the integration and diffusion of technical applications within a complex environment, and (4) the transformation of the operating environment to incorporate the new innovations.

II. METHODOLOGY

A. Medical Consultation WorkStation

Applying the technologies discussed in the Introduction, the TELESYNERGY® Medical Consultation WorkStation (MCWS) was developed at the U.S. National Institutes of Health (NIH) within the Center for Information Technology (CIT) and the NCI [5,6]. The TELESYNERGY® System is a multi-media, medical imaging workstation, used within an electronic imaging environment, and utilizing high-speed networking technologies to establish international links.

We developed both Asynchronous Transfer Mode (ATM) and Integrated Services Digital Network (ISDN) [7] versions of this system. We had previously installed an ATM version of this system in the NCI, Bethesda, Maryland, as well as a number of ATM and ISDN versions at other locations in the U.S., before implementing a telemedicine environment for the newly established Ireland partnership. A diagram of the ATM version of the MCWS is shown in Fig. 1. The Consortium members decided to use this basic system architecture as the telemedicine platform for the NCI All Ireland Cancer Consortium.

The ISDN PRI Version of the MCWS was implemented by simply replacing the Multi Media eXplorer (MMX) fiber-optic ATM audio/video CODEC, with two separate subsystems. The first component is a compact and sophisticated ISDN-capable audio/video CODEC, which meets as a minimum, the ITU H.261 Standard for P*64 KHz Teleconferencing. The second component is an Ethernet ISDN Router. These two elements are interconnected in a fashion which allows their direct insertion into the MCWS architecture, as a simple replacement for the MMX, with no significant wiring changes, other than fiber being replaced by copper, in two places.

The TELESYNERGY® System allows face-to-face consultation among multiple participant sites, while transmitting simultaneous high-resolution images to all sites. It also provides a high-quality teleconferencing facility, which can transmit information and images from several different sources such as a document camera, video recorder, microscope camera and personal computer display.

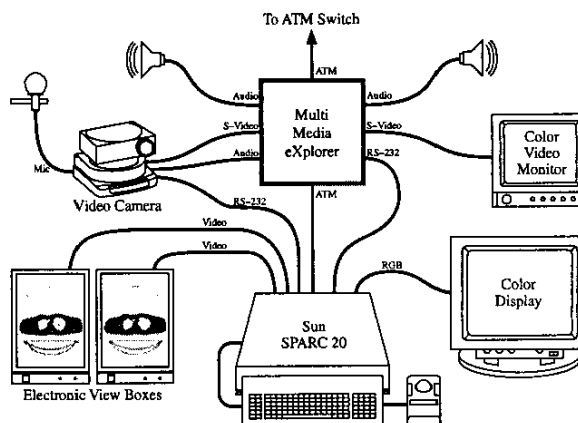

Fig. 1. Diagram of the Medical Consultation Workstation

In addition to standard teleconferencing, diagnostic-quality radiology and pathology images can be transmitted and viewed. Each of the two high-resolution monochrome image displays function as an Electronic View Box (EVB) for the presentation of full-size (14 X 17-inch format) "electronic films." Utilizing these displays, users can perform organ and lesion contouring via a shared-cursor technique, in consultation mode, which allows clinicians to collaborate in feature identification. The identified regions-of-interest are viewed simultaneously and in real-time among all participating TELESYNERGY® sites.

A remote-controlled Olympus microscope with a video camera and remote control module allows users to manipulate and assess biopsy specimens from a number of sites concurrently. A patient exam camera allows high-resolution viewing of dermatologic lesions, skin coloration, and other physical signs during a patient examination. Recorded video images, such as dynamic cardiac ultrasound, can be transmitted for simultaneous review at multiple sites. The initial clinical application area for TELESYNERGY® was in support of radiation treatment planning.

The TELESYNERGY® System possesses functional specifications that represent an improvement over existing video-conferencing technologies. The system can eliminate long delays in potentially critical communications between medical professionals, located in geographically distributed regions, and provides high-resolution medical imagery. On a larger scale, it may help to promote national and international expertise in cancer research and treatment, as well as the adoption of uniform standards of care.

B. Network Connections

We use an ATM network within the NIH campus and the surrounding area, whenever feasible, as the connectivity

mechanism for the TELESYNERGY® System. Audio and video data streams, as well as an IP data path, are implemented bi-directionally through the 155 Megabits/second ATM links connecting the NCI system to local off-campus collaborative sites. Microphones and speakers allow bi-directional voice communication, and video capability is provided with S-video sources and monitors.

We developed a novel ISDN-to-ATM Telemedicine Gateway [8], which effectively splices an ATM network leg into an Integrated Services Digital Network (ISDN) Primary Rate Interface (PRI), to allow the implementation of TELESYNERGY® nodes in regions within the United States and internationally, where ATM networks, supporting the Switched Virtual Circuit paradigm, have not yet been implemented.

Audio and video data streams, as well as IP data paths, continue bi-directionally through the gateway in a transparent fashion. Each of the geographically distant ISDN-based TELESYNERGY® nodes functions seamlessly with the ATM-based TELESYNERGY® nodes that are located within the ATM cloud in Bethesda, Maryland.

The ISDN PRI network topology was selected for the international extension legs of the TELESYNERGY® Environment since it provides the same characteristics as the primary ATM Hub: circuit switching, guaranteed Quality of Service, relatively high bandwidth, and inherent high security.

Within the United States, the ISDN PRI implementation is based upon the T1 circuit, with 23 B Channels and 1 D Channel allocated within a total bandwidth of 1.544 Megabits/second. In Europe, it is based upon the E1 Circuit, with 30 B Channels and 1 D Channel allocated within a total bandwidth of 2.048 Megabits/second.

It was originally necessary to employ a separate Protocol Converter, on the European side of the international ISDN PRI link, to allow U.S. Standard (T1-based) ISDN components to be utilized in Europe. Currently, the protocol conversion is carried out within the ISDN audio/video CODEC. Overall, as a result of efficiency of the unique ISDN-to-ATM Telemedicine Gateway, there is only a slight degradation in video quality, and a reduction in the data rate of the IP pathway to 512 Kilobits/second.

III. RESULTS

A. System Installation

For this international partnership, we installed an ISDN version of the TELESYNERGY® system at the St. Luke's

Hospital, Dublin, Republic of Ireland, and at the Belfast City Hospital, Belfast, Northern Ireland, United Kingdom. The implementation of the two systems in Dublin and Belfast established the first international use of this technology. These ISDN-based systems include a bi-directional IP data path, in addition to the bi-directional audio and video pathways.

As mentioned earlier, we had previously installed an ATM version of this system in the NCI, Bethesda, Maryland, so the NCI already had a system that could be used for collaborating with the two Ireland sites.

B. Using the Telemedicine Environment

The TELESYNERGY® environment has allowed better access to care by removing time and location constraints, providing direct access to the necessary medical expertise and skills, improving direct collaboration and research, facilitating consultation, and allowing Consortium members to access expertise available at the other sites. Complex and rare cases can easily be discussed with a group of experts spread over a large geographic area with all the necessary tools and facilities to allow an in-depth discussion leading to consensus opinion, diagnosis and treatment protocol. Patients can be screened locally for clinical trial eligibility. The environment facilitates clinical research into novel new approaches that may ultimately lead to new treatments.

The collaborative use of the system at the three sites has led to the improvement in quality of care in that each patient, regardless of location, receives an expert assessment and is given optimal therapy. In one particular instance the TELESYNERGY® environment allowed consultants in Northern Ireland to access experts in the NCI for a complex review of a rare cancer case. The consultant in question had not seen the existing illness in 25 years and the direct access to the experts in the NCI allowed for this case to be reviewed, the illness to be correctly diagnosed and a plan formulated for the treatment of the patient. This connection had a direct effect on the treatment of this patient and led to improved quality of care [9].

IV. DISCUSSION

Referring to the framework for understanding the four stages of a successful telemedicine development discussed in the Introduction, we have completed the first two stages in providing a telemedicine environment for the Consortium. We have developed the basic technological capabilities by implementing the TELESYNERGY® system at the three collaborating sites. The medical staff at all three sites are using the systems and developing relevant applications. Medical experts and technical staff at each of the sites are now working to integrate the new applications

within each cancer center. The Consortium participants hope to transform cancer care through the use of the new technology.

The economic benefits of using the telemedicine environment are great considering the improved access to care and quality of care, as the example of the patient in Northern Ireland demonstrates. The traditional approach was for medical experts to travel to the medical center requiring an expert consultation or for the collaborating professionals to meet at a mutually agreed upon site. Distance and time constraints were frequently limiting issues for establishing a collaborative effort.

Consultation over the telephone did not allow professionals to have access to all the necessary information, such as medical images, to properly discuss cases. The implemented telemedicine environment now overcomes these obstacles to collaborative care. Present users include oncologists, radiologists, surgeons, pathologists, radiation therapists, physicists, clinical engineers, biomedical engineers, nurses, medical laboratory staff, and information technology staff.

The TELESYNERGY® System is being used for clinical trials, whose outcomes may lead to innovative new treatment protocols that could improve the prognosis for future cancer patients. It is also being used for long distance educational purposes. NIH hosted a TELESYNERGY® Users Group Meeting in January of this year where participants discussed future plans for the system. The Consortium plans to install additional systems throughout the island, with similar functionality, but with a Personal Computer architecture as the central platform.

In the future, this technology will be applied to many other medical specialties, not just radiation oncology. Some of the additional specialties that could benefit from this environment are cardiology, radiology, ophthalmology, dermatology, histopathology, cytopathology, infectious diseases, otolaryngology, mammography, and additional areas within the oncology domain.

ACKNOWLEDGMENT

The authors would like to gratefully acknowledge the collaboration and important contributions of the following members of the Ireland - Northern Ireland - NCI Cancer Consortium: L. Birthistle, P. Cooney, D. Hollywood, O. Holmberg, B. McClean, and J. McGivney of the St. Luke's Hospital, Dublin, Republic of Ireland; D. Henderson P. Johnston, P. Leighton, S. McAleer, T. Morris, and D. O'Loan of the Belfast City Hospital, Belfast, Northern Ireland, United Kingdom.

REFERENCES

- [1] P. G. Johnston and P. A. Daly, "The NCI-Ireland Consortium: A Unique International Partnership in Cancer Care," *The Oncologist*, vol. 6, pp. 453-458, 2001.
- [2] W. C. Chen, "Telemedicine," in *Wiley Encyclopedia of Electrical and Electronics Engineering*, J.G. Webster, Ed. New York: Wiley and Sons, Inc., 1999, vol. 21, pp. 480-489.
- [3] K. M. Kempner, F. S. Govern, and R. L. Martino, "Telemedicine Systems," in *Introduction to the Principles and Practice of Clinical Research*, J.I. Gallin, Ed. New York: Academic Press, 2002, ch. 22, pp. 361-385.
- [4] S. K. Mun and J. W. Turner, "Telemedicine: Emerging e-medicine," *Annual Review of Biomedical Engineering*, vol. 1, pp. 589-610, 1999.
- [5] K. M. Kempner, D. Chow, P. Choyke, J. R. Cox, J. E. Elson, C. A. Johnson, P. Okunieff, H. Ostrow, J. C. Pfeifer, and R. L. Martino, "The Development of an ATM-based Radiology Consultation Workstation for Radiation Treatment Planning," in *Medical Imaging 1997: Image Display, Proceedings of the Society of Photo-Optical Instrumentation Engineers*, Y. Kin, Ed. Bellingham, Washington: The International Society for Optical Engineering, 1997, vol. 3031, pp. 500-511.
- [6] R. L. Martino, K. M. Kempner, and C. A. Johnson, "Information Technology Applications in Biomedical Research," in *Proceedings of the IEEE Engineering in Medicine and Biology Society Conference on Information Technology Applications in Biomedicine*, Piscataway, New Jersey: IEEE Press, 1998, pp. 28-34.
- [7] W. Stallings, *Data and Computer Communications*, Sixth Edition, Upper Saddle River, New Jersey: Prentice Hall, 2000.
- [8] K. M. Kempner, D. Chow, J. E. Elson, F. S. Govern, M. E. Steele, and R. L. Martino, "Development of a High-Performance ISDN-to-AMT Telemedicine Gateway in Support of the NCI All Ireland Cancer Consortium," *Technology and Health Care*, vol. 9, pp. 46-47, 2001.
- [9] N. Gould, "Doctors in Unique U.S. Video Link Move," *The Belfast Telegraph*, pp. 1, October 21, 2002.